



LEADING PARTICULARS

Maximum take-off weight	29000 lb	13155 kg
Maximum landing weight	28500 lb	12925 kg
Maximum zero fuel weight	26500 lb	12020 kg
Operational empty weight (average)	17100 lb	7755 kg
Maximum payload	9400 lb	4264 kg
Maximum fuel capacity	5690 lb	2580 kg
Maximum cruise speed	283 kt	
Maximum operating altitude	25000 ft	7620 m

AIRFIELD PERFORMANCE

SL, optimal flaps		ISA	ISA+10°C	ISA+20°C
Maximum take-off weight	lb	29000	29000	29000
	kg	13155	13155	13155
Take-off distance required	ft	4320	4575	4800
	m	1315	1395	1465
5000 ft MSL, optimal flaps		ISA	ISA+10°C	ISA+20°C
Maximum take-off weight	lb	29000	29000	28350
	kg	13155	13155	12860
Take-off distance required	ft	5490	6590	6985
	m	1675	2010	2130

SECTOR PERFORMANCE (29,000 lb MTOW)

SL, ISA optimal flaps, max cruise (Includes 100 nm diversion & reserves)		100 nm	200 nm	300 nm	400 nm	500 nm
Take-off weight	lb	27540	28033	28475	28808	29000
	kg	12492	12716	12923	13067	13154
Block fuel	lb	609	1078	1499	1816	1972
	kg	276	489	680	824	895
Block time (4 min ground time)	min	31	53	74	96	122
Passengers with baggage (220 lb/100 kg each)		34	34	34	33	32

CERTIFIED NOISE LEVELS

		Dowty Rotol	Hamilton Sundstrand
Fly-over	EPNdB	78.5	78.3
Sideline	EPNdB	85.9	86.1
Approach	EPNdB	91.6	90.1

PERFORMANCE MODIFICATIONS AVAILABLE

Optional via Saab Service Bulletin:

- Maximum take-off weight increase to 30,000 lb (13,608 kg)
- Gravel runway kit
- Wing tip extensions

PAYLOAD

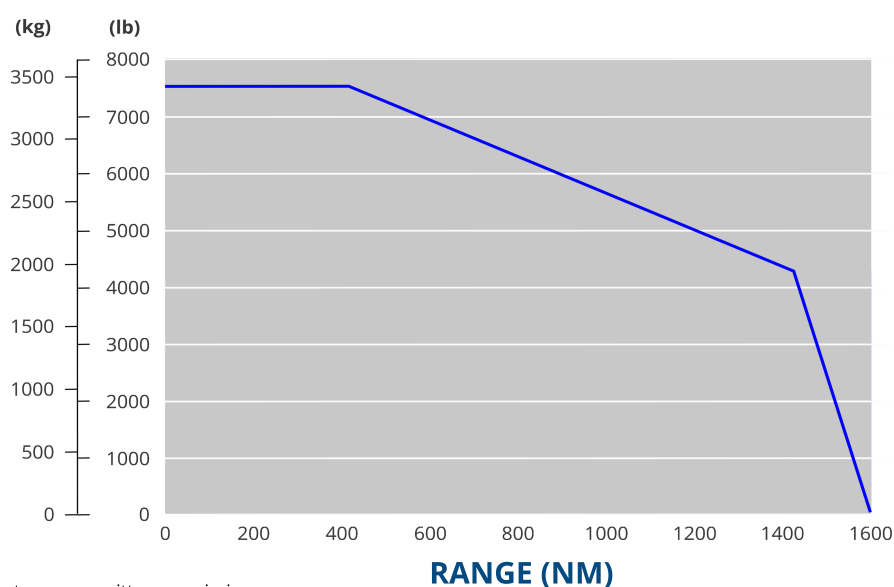



LEADING PARTICULARS

Length	64 ft 9 in	19.73 m
Height	22 ft 11 in	6.97 m
Wing span	70 ft 4 in	21.44 m
Propeller ground clearance	1 ft 8 in	0.51 m
Cargo door (H x W)	51 in x 53 in	1.30 m x 1.35 m
Sill height, passenger door	5 ft 4 in	1.64 m
Sill height, cargo door	5 ft 6 in	1.68 m

Production serial no. SAAB 340B Plus 360-459

ENGINE

(2) GE CT7-9B

Maximum take-off power (ISA, APR) 1870 shp

Propeller Dowty Rotol/
Hamilton Sundstrand

LAYOUT

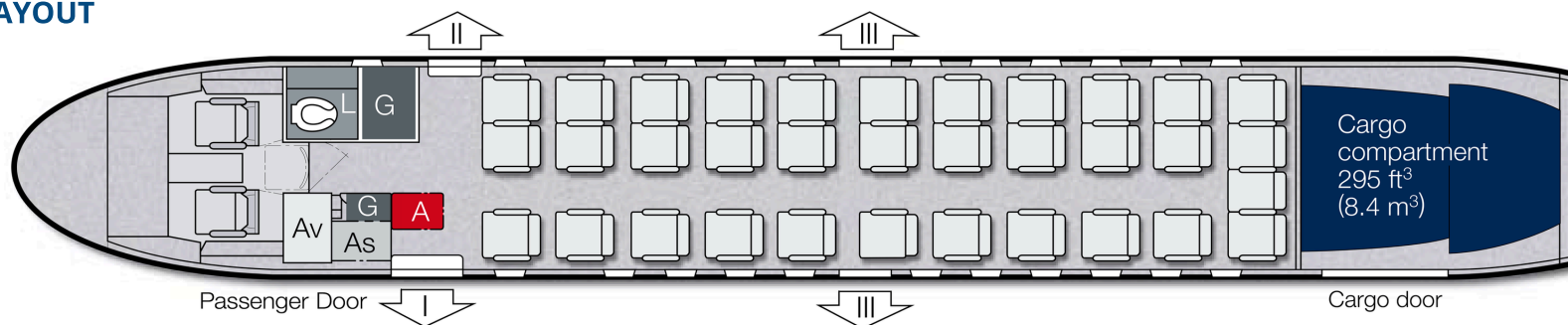

CAPACITY

Cabin length	34 ft 1 in	10.4 m
Cabin width	7 ft 1 in	2.2 m
Headroom	6 ft 0 in	1.8 m
Aisle width	16.3 in	0.4 m
Max cabin pressure differential	7.0 psi	49.2 kPa
Cabin volume	1180 cu ft	33.4 cu m

BAGGAGE VOLUME

Overhead bin	35.3 cu ft	1.01 cu m
Underseat	42.3 cu ft	1.20 cu m
Rear cargo	295 cu ft	6.35 cu m
Baggage vol / pax fwd lav	11.0 cu ft	0.32 cu m

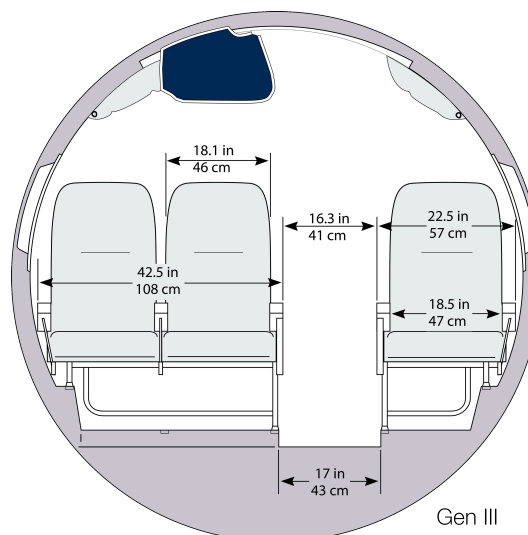

The contents of this data sheet are based on the latest information available to Jetstream Aviation Capital. While given in good faith, it should not be taken as establishing any commitment on the part of Jetstream Aviation Capital or used for flight operations.

©2021 Jetstream Aviation Capital. May not be distributed or reproduced in whole or part without express written permission.